

No. 341 Reamer

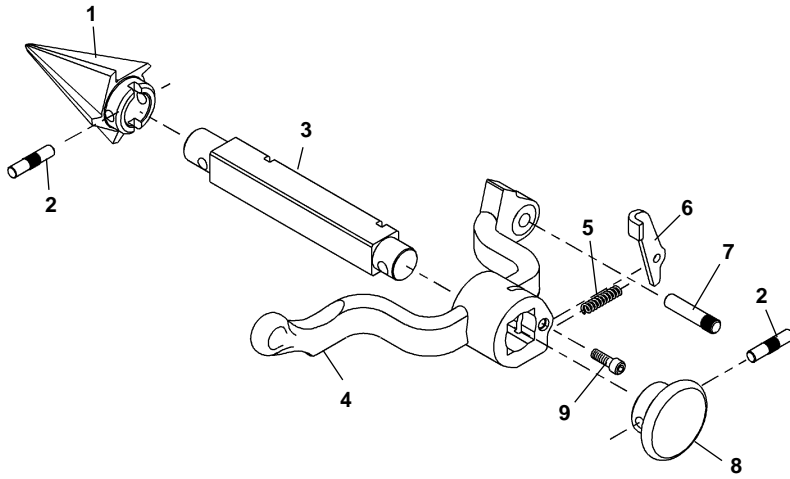

**NOTE: Order parts by Catalog Number only.
DO NOT order by Reference Number.**

Ref. No.	Catalog No.	Description
—	42365	341 Reamer Complete
1	36277	Cone (R.H.)
	46660	Cone (L.H. & R.H.)
2	47155	Pin
3	43790	Reamer Bar
4	43230	Reamer Arm
5	44700	Latch Spring
6	46665	Reamer Latch
7	47065	Hinge Pin
8	46585	Reamer Knob
9	46515	Screw 1/4" - 20 x 3/4"

No. 820 Cutter

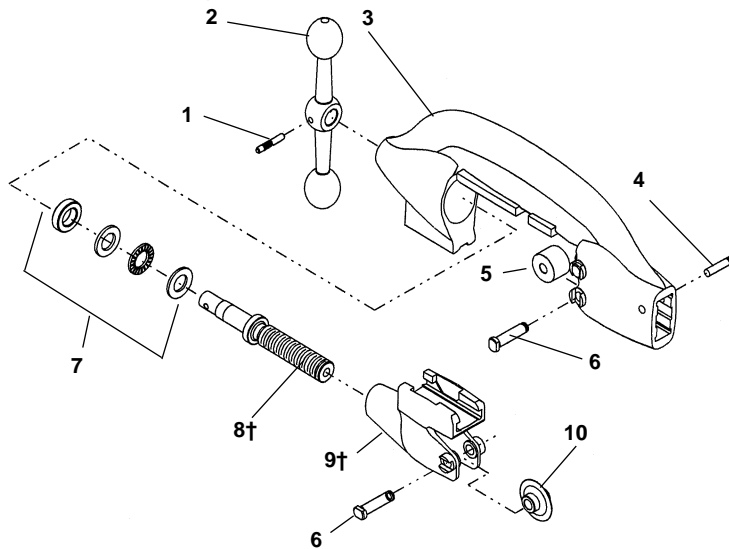

Ref. No.	Catalog No.	Description
—	42390	820 Cutter Complete
1	47160	Crank Pin
2	45765	Feed Screw Crank
3	43040	Cutter Frame
4	47135	Stop Pin
5	34775	Cutter Roll (2)
6	34780	Cutter & Roll Pin (3)
7	46725	Thrust Bearing Assembly
8†	45780	Feed Screw
9†	43245	Wheel Housing
10	44185	Cutter Wheel
	44190	Cutter Wheel f/Stainless

† Service Note: When replacing parts on early style (fine thread) cutters, both feed screw and wheel housing must be replaced.